

July 26, 1966

W. O. BENNETT ET AL

3,262,259

TIME SETTING MECHANISM FOR ELECTRONIC TIMEPIECES

Filed Feb. 10, 1965

3 Sheets-Sheet 1

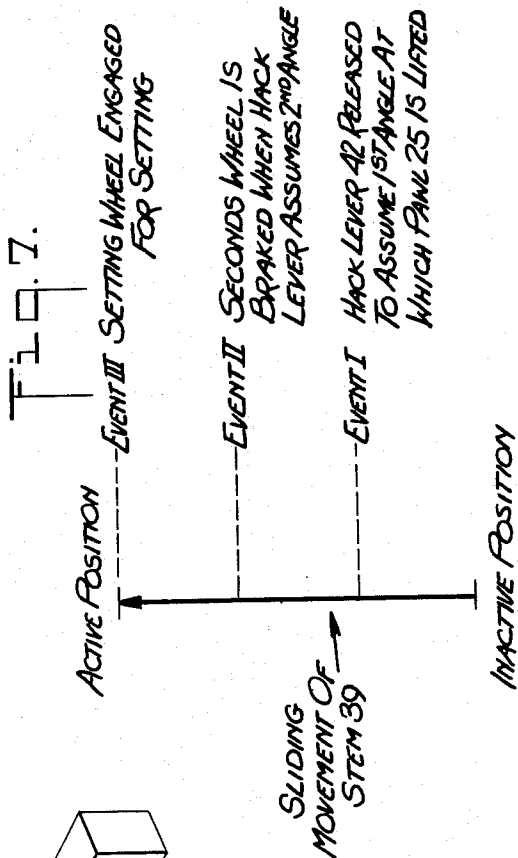
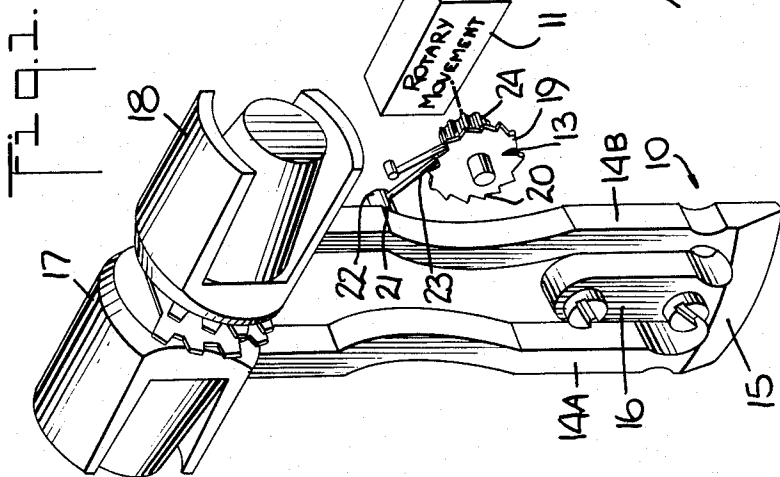
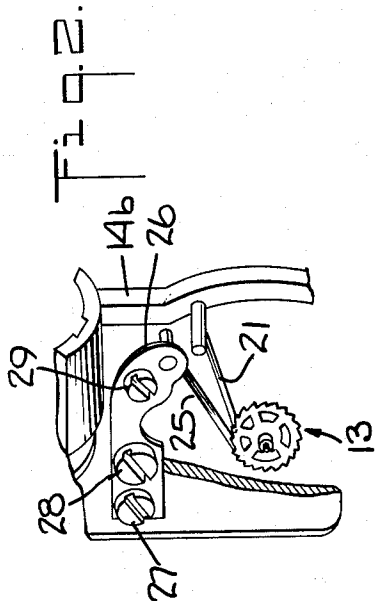

INVENTORS
 WILLIAM O. BENNETT
 BY WILLIAM W. MUTTER
Michael E. ...
 ATTORNEY

July 26, 1966

W. O. BENNETT ET AL

3,262,259

TIME SETTING MECHANISM FOR ELECTRONIC TIMEPIECES

Filed Feb. 10, 1965

3 Sheets-Sheet 2

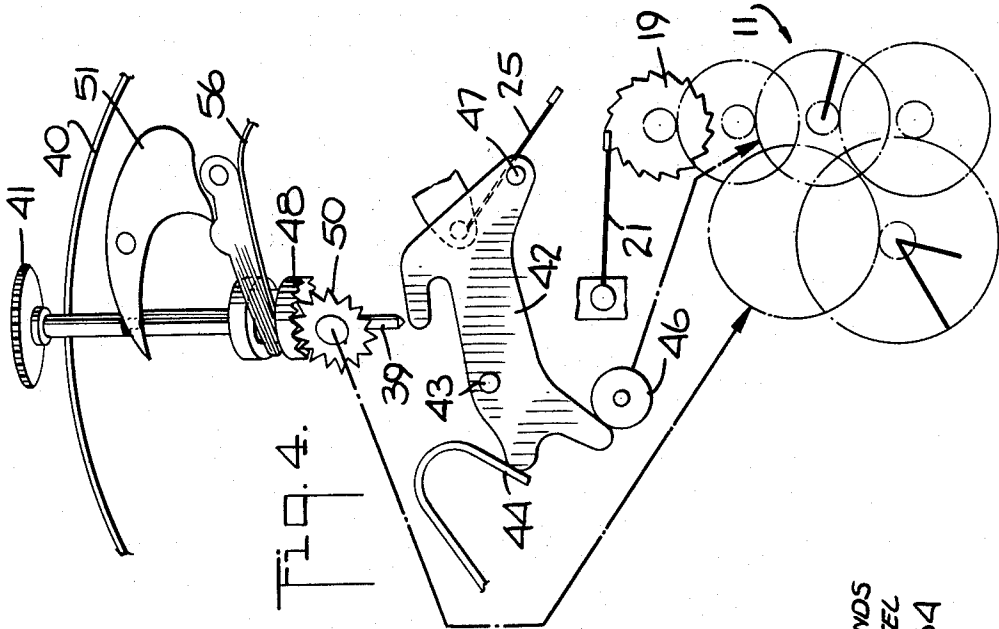

FIG. 4.

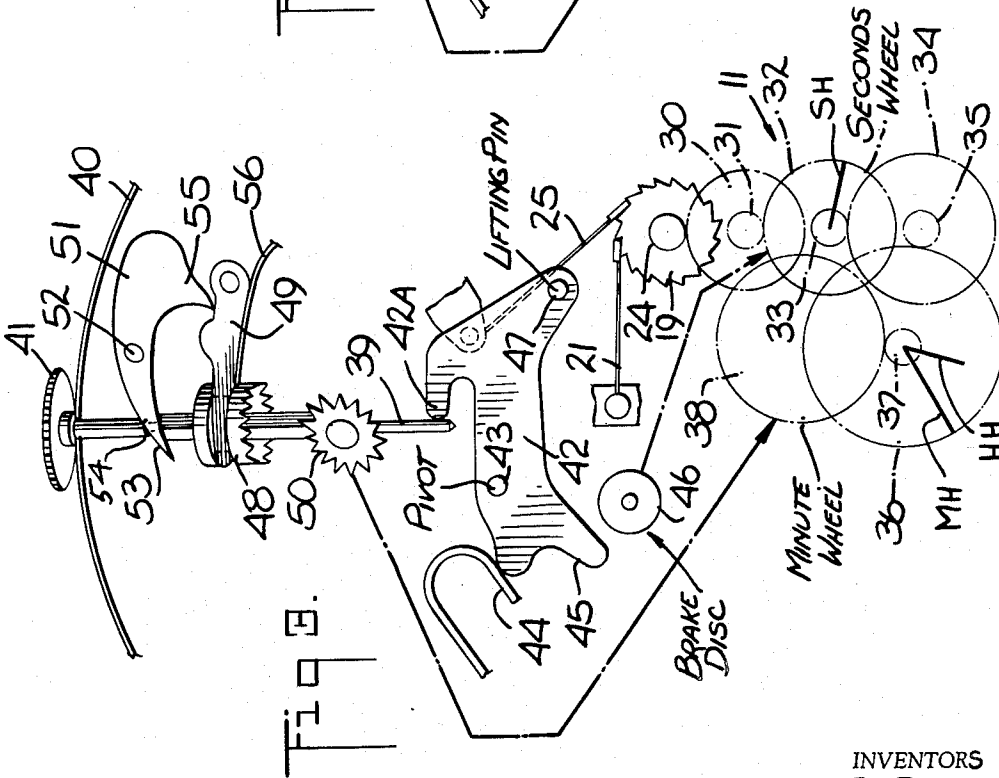

FIG. 5.

INVENTORS
WILLIAM O. BENNETT
BY WILLIAM W. MUTTER
William W. Mutter
ATTORNEY

July 26, 1966

W. O. BENNETT ET AL

3,262,259

TIME SETTING MECHANISM FOR ELECTRONIC TIMEPIECES

Filed Feb. 10, 1965

3 Sheets-Sheet 3

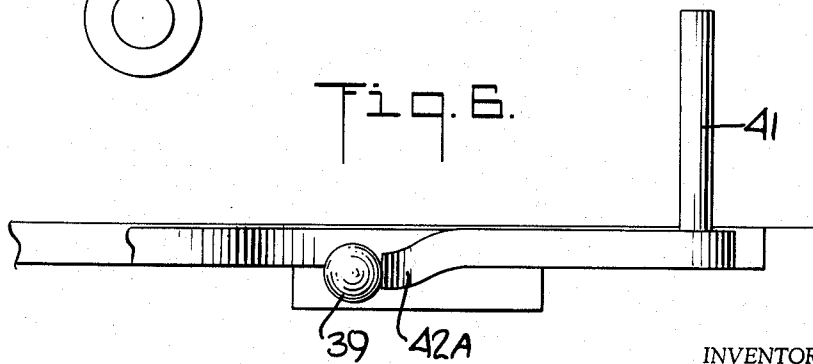
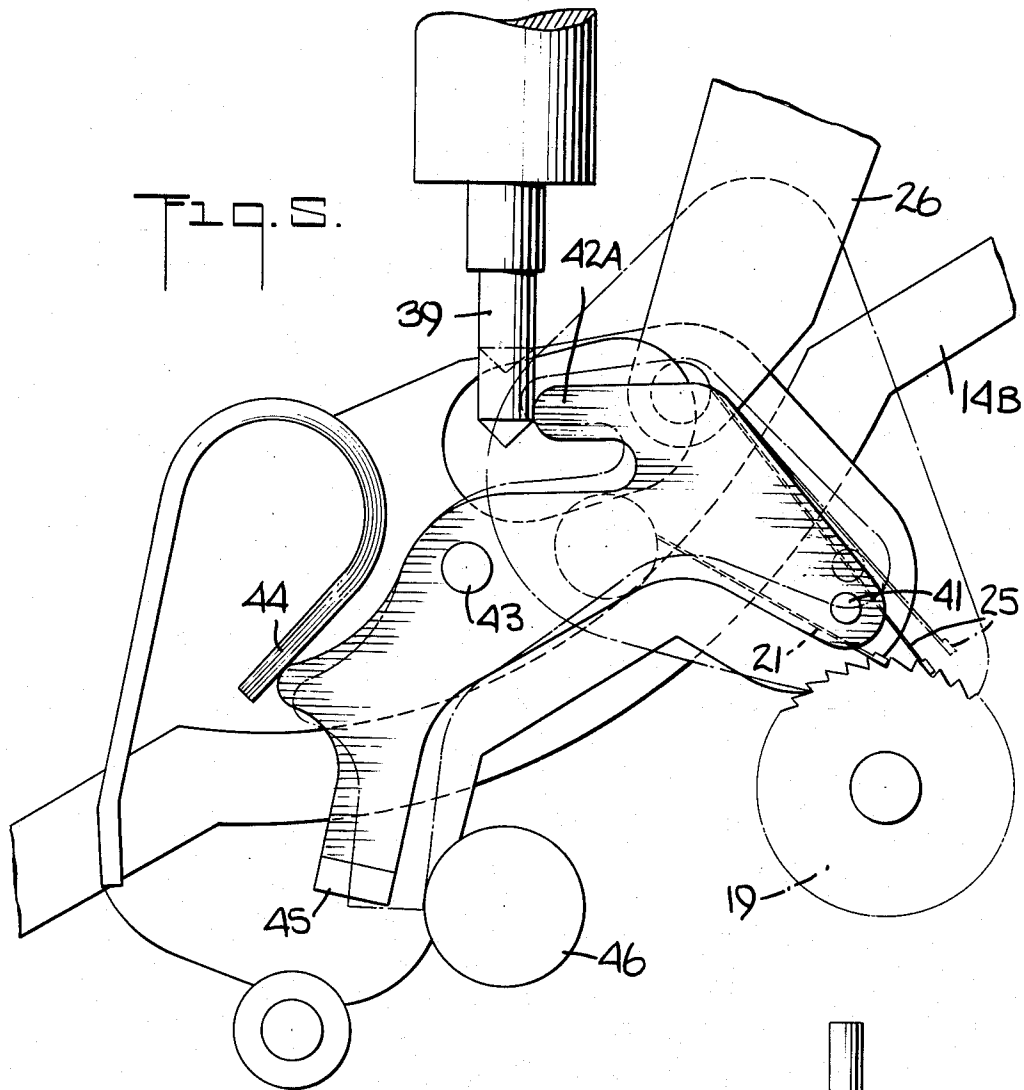

INVENTORS
WILLIAM O. BENNETT
BY WILLIAM W. MUTTER
Michael E. ...
ATTORNEY

1

2

3,262,259

TIME SETTING MECHANISM FOR ELECTRONIC TIMEPIECES

William O. Bennett, Bayside, N.Y., and William W. Mutter, Paramus, N.J., assignors to Bulova Watch Company, Inc., New York, N.Y., a corporation of New York

Filed Feb. 10, 1965, Ser. No. 431,676
5 Claims. (Cl. 58—85.5)

This invention relates generally to time-setting mechanisms for electronic timepieces, and more particularly to a mechanism which when actuated immediately arrests the motion of the seconds hand in a tuning-fork type of electronic timepiece, normal motion of the seconds hand being resumed the moment the setting mechanism is released.

In Patent 2,971,323 of Hetzel, there is disclosed an electronic timepiece including a tuning fork having a relatively high frequency and a battery-powered transistorized drive circuit to sustain the vibratory motion of the fork. The reciprocating motion of the fork, which acts as a time-keeping standard, is transformed into rotary motion by means of a ratchet and pawl mechanism whose pawl or index finger is attached to one tine of the fork. The pawl engages and advances a ratchet wheel provided with a pinion for operating the timepiece hands through a train of gears.

In the co-pending application Serial No. 302,956, filed August 19, 1963, now Patent No. 3,184,981 by Bennett, Mutter and Van Haaften, there is disclosed an improved form of a motion converter for a timepiece of the above-described type, whereby the ratchet wheel is caused to advance only one tooth for each forward stroke of the index finger attached to the tine, regardless of minor variations in the length of the stroke arising from changes in the amplitude of fork vibration. This is accomplished by means of an auxiliary pawl attached to the framework or pillar plate of the timepiece, this pawl engaging the ratchet wheel at a position relative to the index finger at which the phase between the finger and pawl is several ratchet teeth plus one-half tooth.

Various forms of setting mechanisms have heretofore been developed for tuning-fork electronic watches of the type having an index finger to advance an index wheel and a pawl to prevent retrograde motion of the wheel. Such mechanisms, when the setting stem is pulled up, act to effect disengagement both of the pawl and the index finger from the index wheel. Such disengagement is accomplished by means of a lever coupled to the setting stem, the lever being provided with lifting pins which when the stem is raised, serve to lift the index finger and pawl away from the ratchet teeth of the index wheel.

Inasmuch as the pawl which acts to prevent retrograde motion of the wheel is attached to the fixed frame of the watch, the lifting thereof has no adverse effects. However, the index finger is attached to one tine of the tuning fork and when this element is lifted, the index finger continues to reciprocate, the finger then proceeding to drag back and forth across the lifting pin. This drag imposes a relatively heavy load on the tuning fork, thereby reducing its vibratory amplitude and increasing battery drain. When thereafter the index finger is returned to its operative position, its action is initially relatively sluggish until such time as the fork is able to regain its original amplitude. As a consequence, the timepiece does not immediately resume its proper functioning when restarted by the setting mechanism and some degree of accuracy is lost in the setting operation.

In view of the foregoing, it is the main object of this invention to provide a setting mechanism for an electronic timepiece which is adapted to stop, set and precisely restart the timepiece hands.

More specifically, it is an object of this invention to provide a setting mechanism which acts to disengage the pawl of the timepiece without, however, disengaging the index finger, whereby rotation of the index wheel is nevertheless arrested, the mechanism also acting to brake the seconds hand to permit precise setting of the timepiece.

A significant feature of the invention resides in the fact that as the stem of the setting mechanism is raised, a programmed sequence of events takes place in the following order:

First, the pawl is lifted from the index wheel, and since retrograde motion is no longer prevented, the wheel under the action of the index finger, which remains engaged, is caused to oscillate back and forth without, however, advancing.

Second, a brake is applied to the seconds hand wheel or elsewhere in the gear train, at which point the seconds hand is locked in position.

Third, the clutch wheel on the stem is caused to engage the setting wheel in the train to permit turning of the minute and hour hands, while the seconds hand is held at rest, thus making possible a precise setting of the timepiece.

When the stem is returned to its initial position, the above events take place in reverse sequence wherein first the clutch wheel is disengaged, thereby freeing the minute and hour hands, the brake is then released thereby freeing the seconds hand, and finally the pawl re-engages the index wheel and the timepiece is again operative.

It is important to note that the action of the setting mechanism does not affect the index finger, hence no increase in load is imposed on the tuning fork during setting, and when the setting stem is pushed in, the watch immediately resumes operation at its normal rate. Thus, it becomes possible not only to precisely set the timepiece, but to bring about an instant restart without loss in precision.

For a better understanding of the invention, as well as other objects and further features thereof, reference is made to the following detailed description to be read in conjunction with the accompanying drawings, wherein:

FIG. 1 is a perspective view of a tuning fork and motion converter of the type disclosed in said co-pending application;

FIG. 2 separately shows the motion converter;

FIG. 3 schematically shows the setting mechanism in accordance with the invention, when the stem is fully pushed in and the timepiece is operative;

FIG. 4 schematically shows the same time-setting mechanism when the stem is pulled out to permit manual time setting of the minute and hour hands;

FIG. 5 is an enlarged elevational view of that portion of the time-setting mechanism which lifts the pawl and brakes the seconds hand;

FIG. 6 is a section taken along the plane indicated by line 6—6 in FIG. 5; and

FIG. 7 diagrammatically shows the sequence of events when operating the setting mechanism.

The motion transformer

Referring now to FIGS. 1 and 2, there is shown a timepiece of the type disclosed more fully in the above-identified patent and co-pending application, including a tuning fork, generally designated by numeral 10, a rotary movement of conventional design in the form of a gear train 11 for turning the hands of the timepiece, and a motion transformer, generally designated by numeral 13, operatively intercoupling the fork 10 and the rotary movement 11 and acting to convert the vibratory action of the fork into rotary motion. The tuning fork has no pivots or bearings and its timekeeping action is therefore relatively independent of the effects of friction.

Tuning fork 10 is provided with a pair of flexible tines 14A and 14B interconnected by a relatively inflexible base 15, the base being provided with an upwardly extending stem 16 secured to the pillar plate or the framework by suitable screws. The central area of the pillar plate is cut out to permit unobstructed vibration of the tines.

The tuning fork is electromagnetically actuated through an electronic circuit of the type disclosed in the above-noted Hetzel patent, including a magnetic element 17 secured to the free end of tine 14A, and a magnetic element 18 secured to the free end of tine 14B. The manner in which the fork or other vibratory member is sustained in vibration forms no part of the present invention.

The vibratory motion of the tuning fork is converted by motion transformer 13 into rotary motion. This transformer is constituted by a ratchet and pawl mechanism operated by the tuning fork to drive an index wheel 19 having ratchet teeth 20 thereon. In a working embodiment, the wheel has a large number of teeth (300) and yet a diameter of only $\frac{95}{1000}$ of an inch, the length of each tooth being $\frac{8}{10,000}$ of an inch.

Index wheel 19 acts as the actuator for rotary movement 11, and it is therefore intended that this wheel be advanced by the vibratory fork at a constant rate. This is effected by means of the main pawl or index finger 21, one end of which is secured to a post 22 projecting laterally from the tine 14B.

Index finger 21 is in the form of a light leaf spring and carries a tip 23 which may be of precious or semi-precious stone, such as sapphire. The tip engages the teeth 20 of index wheel 19, so that the oscillations of the tine transmit turning impulses to the wheel. The shaft of wheel 19 is provided with a pinion 24 which intermeshes with the first gear in the gear train 11.

Operating in conjunction with index wheel 19 is an auxiliary pawl 25 whose design is similar to that of the index finger 21, the pawl being secured to a bridge 26 pivotally attached to the pillar plate. The position of bridge 26 may be adjusted by means of cam member 27 and locked by locking screws 28. Bridge 26 pivots about screw 29.

The index finger and pawl are both tensioned downwardly, the jewelled tips thereof being parallel with the teeth of the index wheel. The tension is such that when the finger is retracted, there is sufficient reverse torque to cause the wheel to reverse direction. This back-up, however, is arrested by the pawl which is phased several teeth plus one-half tooth from the finger. It would not be practical to maintain an exact amplitude for vibrations of the tuning fork in a wrist timepiece and the operation of the motion transformer is such that this is not necessary.

It will be noted that the spring forces on the index finger 21 and pawl 25 not only hold them in firm contact with the index wheel 19, but they also exert a torque on this wheel, in the direction opposite to its forward motion. This torque causes the index wheel to back up during the first portion of the return stroke of the index jewel, until it is engaged by the pawl jewel. This torque is the result of the geometry of the system and is similar to the "draw" in a conventional escapement which tends to hold the pallet fork against the banking pin.

The time-setting mechanism

Referring now to FIG. 3, the time-setting mechanism is shown in its pushed-in or inactive position, in which state the timepiece operates normally with all hands in motion. Thus the reciprocating index finger 21 engages the ratchet teeth of index wheel 19 to advance same. Retrograde motion of the wheel is prevented by pawl 25 which also engages the ratchet teeth of the wheel at a point thereon displaced from that of the index finger which is adjusted to provide the proper phase relationship therebetween in the manner disclosed in the above-identified co-pending application.

The gearworks 11, which is of conventional design and hence will not be described in complete detail, acts

to turn an hour hand HH, a minute hand MH, and a sweep second hand SH. The regulated driving power to operate these hands is transmitted through pinion 24 on the shaft of the index wheel 19, this pinion engaging wheel 30. The pinion 31 on the shaft of the wheel 30 engages the seconds wheel 32. The pinion 33 on the shaft of the seconds wheel engages the third wheel 34, and its pinion 35 engages the center wheel 36. The cannon pinion 37 of the center wheel engages a minute wheel 38, and its pinion (not shown) engages an hour wheel (not shown) with its hour hand tube or pipe. The cannon pinion, or the minute hand shaft, is held by friction in the usual way to the center wheel. Hence as the ratchet wheel turns, this motion is transmitted through the gear train to the seconds, minute and hour hands, whereby for each full sweep of the seconds hand, the minute hand moves one-sixtieth of a full revolution, and for each full revolution of the minute hand, the hour hand moves one-twelfth of a revolution.

The time-setting mechanism includes a stem assembly constituted by a slidable stem 39 whose upper end extends through an opening in the watch casing 40 and terminates in a crown 41. A hack lever 42 is mounted on a pivot 43 and is tensioned by a spring 44 such that projection 42A thereon bears against the lower portion of stem 39 when the stem is in its inactive position, whereby when the stem is retracted from projection 42A, the hack lever is free to swing in the manner shown in FIG. 4, to cause a shoe portion 45 thereof to engage a brake disc 46 mounted on the shaft of the seconds wheel and to cause a lifting pin 47 to engage the pawl 25 and to lift it away from the teeth on ratchet wheel 19.

Mounted on a square portion of the stem 39 is a clutch wheel 48 which is free to slide but not to rotate thereon. Clutch wheel 48 is caused by clutch lever 49, when the stem is fully raised to its pull-out or active position, to engage a setting wheel 50. Setting wheel 50 intermeshes with minute wheel 38, hence when the crown 41 is manually rotated, the minute wheel is caused to turn to set the minute and hour hands in the usual manner. Clutch lever 49 is operated by a setting lever 51 which rocks about a pivot 52, the nose 53 of this lever being received within an annular groove 54 on the stem, such that when the stem is raised, a projection 55 on the setting lever rides on the cam surface of the clutch lever 49, forcing the clutch lever down against the action of the setting lever spring 56, thereby putting clutch wheel 48 into mesh with the setting wheel 50. A detent (not shown) is provided to hold setting lever 51 in its operative position.

Thus in the pushed-in or inactive position of the stem 39, as shown in FIG. 3, the stem extends beneath the projection 42A of the hack lever 42, thereby holding this lever in angular position about its pivot 43, at which position brake drum 46 is disengaged, lifting pin is displaced from the pawl 25, and the setting wheel 50 is decoupled from clutch wheel 48, so that the timepiece is free to operate in its usual manner.

When the stem is raised from its inactive position, as shown in FIG. 4, three events occur in the course of the upward movement of the stem. These events take place in a programmed sequence in which is determined by the physical parameters of the stem assembly and hack lever. These events and their sequence are shown in FIG. 7 and will now be described.

Event 1.—When the stem is partially lifted from its inactive position and before it is sufficiently raised to its active position to cause clutch wheel 48 to engage the setting wheel 50, the stem is retracted from projection 42A to release the hack lever 42. The position of lifting pin 47 relative to pawl 25, as against the position of shoe 45 relative to brake drum 46, is such that the first event, which occurs in the course of the swing of the hack lever, is the lifting of the pawl. As a consequence, retrograde motion of the index wheel is no longer prevented, and even though the wheel is still driven by the index finger 21, the downward tension of this finger imposes a reverse torque on the

wheel and the wheel is caused to oscillate rather than to turn. Hence the tuning fork is effectively decoupled and the timepiece hands cease turning upon occurrence of the first event.

Event II.—In event I, the stem is only partially raised, and while the setting wheel is not yet operative, the hack lever has been released and has swung to a degree sufficient to effect lifting of the pawl. With the completion of the hack-lever swing, the shoe 45 engages brake disc 46, which is mounted on the shaft of the seconds wheel, and arrests further movement of the seconds hand. Hence the indication of the seconds hand will not thereafter be changed while the minute and hour hands are adjusted.

Event III.—Finally, when the stem is pulled up fully to the active position where the clutch wheel 48 on the stem meshes with setting wheel 50, rotation of the crown 41 will bring about rotation of the minute wheel 38 and hence setting of the minute and hour hands, without however changing the held position of the seconds hand. In this way it becomes possible to precisely set the watch. It is important to note that the hack lever completes its swing to carry out the first and second events before the third event takes place.

After the watch is set and the stem is returned from its pulled-out (active) to its pushed-in (inactive) position, the above events occur in reverse order, the setting wheel first being disengaged, the seconds wheel then being released, and finally the pawl returned to the ratchet teeth on the index wheel to cause resumption of operation.

While there has been shown and described a preferred embodiment of time-setting mechanism for electronic timepieces in accordance with the invention, it will be appreciated that many changes and modifications may be made therein without, however, departing from the essential spirit of the invention as defined in the annexed claims.

What we claim is:

1. A time-setting mechanism for an electronic timepiece, wherein an index finger attached to a vibratory element engages the ratchet teeth on an index wheel operatively coupled to a gear train having a minute wheel and a seconds wheel and wherein a pawl also engages said teeth to prevent retrograde motion of said index wheel, said mechanism comprising:

- (A) first means adapted to lift said pawl away from said ratchet wheel to prevent rotation of said index wheel without disengagement of said index finger,
- (B) second means adapted to brake said seconds wheel,
- (C) third means adapted to engage and turn said minute wheel to adjust the minute and hour hands of the timepiece, and
- (D) control means operatively coupled to said first, second and third means to actuate same without interfering with the action of said index finger, said control means being adapted to stop said timepiece and to permit setting thereof by rendering said first, second and third means operative in the named sequence, and adapted to restart said timepiece after the setting thereof by rendering said third, second and first means inoperative in the named sequence.

2. A time-setting mechanism for an electronic timepiece, wherein an index finger attached to a tine of a tuning fork whose vibration is sustained engages the ratchet teeth on an index wheel operatively coupled to a gear train having a minute wheel coupled to the minute and hour hands and a seconds wheel coupled to a sweep second hand, and wherein a pawl also engages said teeth to prevent retrograde motion of said index wheel, said mechanism comprising:

- (A) first means adapted to lift said pawl away from said ratchet wheel to prevent rotation of said index wheel without disengaging the index finger from the ratchet wheel,
- (B) second means adapted to brake said seconds wheel and thereby arrest the motion of the seconds hand,
- (C) third means adapted to engage and turn said

minute wheel to adjust the minute and hour hands of the timepiece, and

- (D) control means operatively coupled to said first, second and third means to actuate same without interfering with the action of said index finger, said control means including a slidable stem adapted to stop said timepiece and to effect setting thereof by rendering said first, second and third means operative in the named sequence when said stem is pulled out, and to restart said timepiece after the setting thereof by rendering said third, second and first means inoperative in the named sequence when the stem is pushed in.

3. A time-setting mechanism for an electronic timepiece, wherein an index finger attached to a vibratory element engages the ratchet teeth on an index wheel operatively coupled to a gear train having a minute wheel coupled to minute and hour hands, and a seconds wheel coupled to a sweep second hand and wherein a pawl also engages said teeth to prevent retrograde motion of said index wheel, said mechanism comprising:

- (A) first means including a lifting pin to lift said pawl away from said ratchet wheel to prevent rotation of said index wheel without disengagement of said finger,
- (B) second means including a brake shoe and a brake disc coupled to said seconds wheel to arrest the motion thereof,
- (C) third means including a clutch to engage and turn said minute wheel to adjust the minute and hour hands of the timepiece, and
- (D) control means operatively coupled to said first, second and third means to actuate same without interfering with the action of said index finger, said control means being adapted to stop said timepiece and to effect setting thereof by rendering said first, second and third means operative in sequence and to restart said timepiece after the setting thereof by rendering said third, second and first means inoperative in sequence.

4. An electronic timepiece comprising:

- (A) a tuning fork whose vibration is sustained to provide a timekeeping standard,
- (B) a rotary gear train for operating the hour, minute and seconds hands of the timepiece and including,
 - (a) a minute wheel whose rotation effects adjustment of said minute and hour hands, and
 - (b) a seconds wheel whose rotation effects adjustment of said seconds hand,
- (C) a motion transformer to convert the vibratory motion of the fork into rotary motion for driving said gear train and including,
 - (a) an index wheel having ratchet teeth, said wheel being operatively coupled to said train,
 - (b) an index finger attached to one tine of the fork and engaging the teeth of said index wheel at a point thereon, and
 - (c) a pawl fixedly attached on said timepiece and engaging the teeth of said index wheel at another point thereon to prevent retrograde motion of said wheel, and
- (D) a time-setting mechanism for said timepiece to precisely set same, said mechanism including,
 - (a) a setting wheel operatively coupled to minute wheel,
 - (b) a stem assembly provided with a stem which is slidable from an inactive to an active position and having a clutch wheel thereon which is caused to engage said setting wheel only when said stem occupies said active position to permit adjustment of the minute and hour hands,
 - (c) a pivoted hack lever having a brake shoe and a lifting pin thereon, said pin being arranged to lift said pawl from said ratchet wheel

7

when said lever occupies a first angular position without interfering with the action of said index finger, and said shoe being arranged to brake said seconds wheel when said lever occupies a second angular position,

(d) means maintaining said lever in an inactive position when said stem is in an inactive position and releasing said lever to swing sequentially into said first and second angular positions when said stem is partially raised but before said stem occupies its active position.

5. An electronic timepiece comprising:

(A) a tuning fork whose vibration is sustained to provide a timekeeping standard,

(B) a rotary gear train for operating the hour, minute and seconds hands of the timepiece and including,

(a) a minute wheel whose rotation effects adjustment of said minute and hour hands,

(b) a seconds wheel whose rotation effects adjustment of said seconds hand,

(C) a motion transformer to convert the vibratory motion of the fork into rotary motion for driving said gear train and including,

(a) an index wheel having ratchet teeth, said wheel being operatively coupled to said train,

(b) an index finger attached to one tine of the fork and engaging the teeth of said index wheel at a point thereon, and

(c) a pawl fixedly attached on said timepiece and engaging the teeth of said index wheel at another point thereon to prevent retrograde motion of said wheel, and

(D) a time-setting mechanism for said timepiece to precisely set same, said mechanism including,

(a) a setting wheel operatively coupled to minute wheel,

8

(b) a brake disc coupled to the shaft of the seconds wheel,

(c) a stem assembly provided with a stem which is slidable from an inactive to an active position and having a clutch wheel thereon which is caused to engage said setting wheel only when said stem occupies said active position to permit adjustment of the minute and hour hands,

(d) a pivoted back lever having a brake shoe and a lifting pin thereon, said pin being arranged to lift said pawl from said ratchet wheel when said lever occupies a first angular position without interfering with the action of said index finger, and said shoe being arranged to engage said brake disc to brake said seconds wheel when said lever occupies a second angular position,

(e) means maintaining said lever in an inactive position when said stem is in an inactive position and releasing said lever to swing sequentially into said first and second angular positions when said stem is partially raised but before said stem occupies its active position, whereby when said stem slides from said inactive to active position of said pawl is lifted, then said second wheel is braked and finally said minute wheel is engaged to permit setting of the timepiece.

References Cited by the Examiner

FOREIGN PATENTS

955,367 4/1964 Great Britain.

LOUIS J. CAPOZI, *Primary Examiner.*

GERALD F. BAKER, *Examiner.*