

# T-1<sup>3</sup>/<sub>4</sub> (5 mm) SiC Blue LED Lamps

## Technical Data

**HLMP-DB00**  
**HLMP-DB15**

### Features

- Silicon Carbide Technology
- 481 nm Blue Color
- Viewing Angles: Narrow and Wide
- CMOS/MOS Compatible

### Applications

- Moving Message Signs
- Automotive Interior Lighting
- Front Panel Status Indicator
- Medical Instrumentation

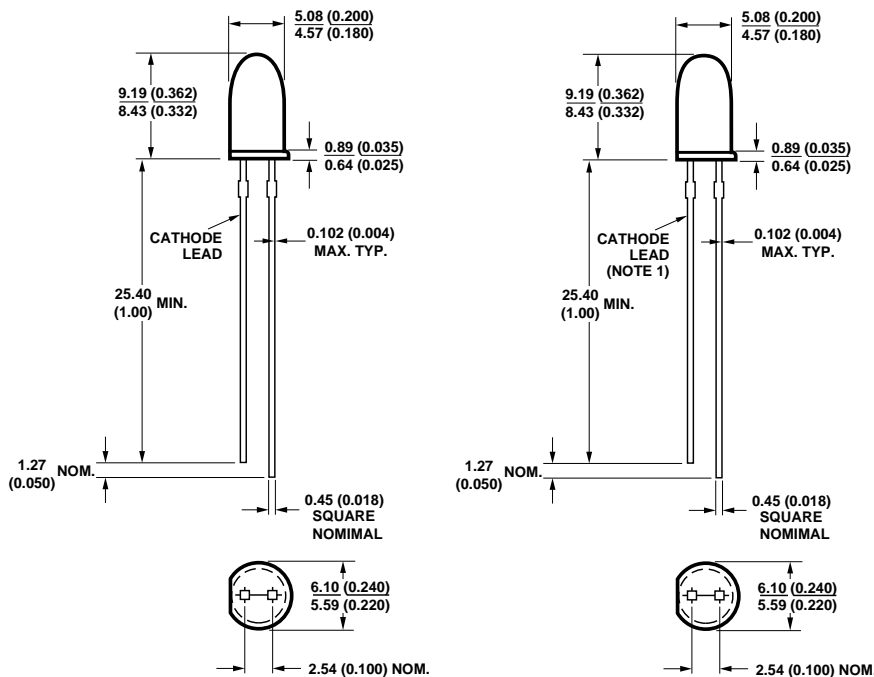

**NOTES:**

1. ALL DIMENSIONS ARE IN MILLIMETERS (INCHES).
2. THE LEADS ARE MILD STEEL, SOLDER DIPPED.
3. AN EPOXY MENISCUS MAY EXTEND ABOUT 1 mm (0.040") DOWN THE LEADS.

### Description

These untinted diffused and nondiffused T-1<sup>3</sup>/<sub>4</sub> LED blue lamps utilize single crystal silicon carbide technology. The color is an 80% saturated blue with a dominant wavelength of 481 nanometers. The HLMP-DB00 is a 38 degree cone angle diffused lamp for use in moving message panel signs or as a front panel indicator. The HLMP-DB15 is a nondiffused lamp with a 15 degree cone angle that may be used for backlighting legends or as a blue wavelength emitter.

**HLMP-DB15**

**HLMP-DB00**

### Absolute Maximum Ratings at $T_A = 25^\circ\text{C}$

DC Forward Current <sup>[1]</sup> .....	50 mA
Peak Forward Current <sup>[2]</sup> .....	100 mA
Average Forward Current (@ $I_{\text{PEAK}} = 100 \text{ mA}$ , $f = 1 \text{ KHz}$ ) <sup>[2]</sup> .....	40 mA
LED Junction Temperature.....	110°C
Transient Forward Current (10 $\mu\text{s}$ Pulse) <sup>[3]</sup> .....	500 mA
Reverse Voltage ( $I_R = 100 \mu\text{A}$ ).....	5 V
Operating Temperature Range.....	-55 to 85°C
Storage Temperature Range.....	-55 to 100°C
Lead Soldering Temperature (1.59 mm [0.063 in.] from body).....	260°C for 5 seconds

**Notes:**

1. Derate linearly as shown in Figure 5.
2. Refer to Figure 6 to establish pulsed operating conditions.
3. The transient peak current is the maximum non-recurring peak current the device can withstand without damaging the LED die and wire bonds. Operating the device at peak currents above the absolute Maximum Peak Forward Current is not recommended.

### Optical Characteristics at $T_A = 25^\circ\text{C}$

Part Number HLMP-	Luminous Intensity $I_v$ (mcd) @ $I_F$ 20 mA <sup>[1]</sup>		Radiant Intensity $I_e$ ( $\mu\text{W}/\text{sr}$ ) @ 20 mA Typ.	Total Flux $\phi_v$ (mIm) @ 20 mA <sup>[2]</sup> Typ.	Color, Dominant Wavelength $\lambda_d$ <sup>[3]</sup> (nm) Typ.	Peak Wavelength $\lambda_{\text{PEAK}}$ (nm) Typ.	Viewing Angle $2\theta_{1/2}$ Degrees <sup>[4]</sup> Typ.
	Min.	Typ.					
DB00	1.0	3.0	23.1	2.0	480	470	38
DB15	6.3	12.0	93.3	2.0	480	470	15

**Notes:**

1. The luminous intensity,  $I_v$ , is measured at the peak of the spatial radiation pattern which may not be aligned with the geometric axis of the lamp package.
2.  $\phi_v$  is the total luminous flux output as measured with an integrating sphere.
3. The dominant wavelength,  $\lambda_d$ , is derived from the CIE Chromaticity Diagram and represents the color of the device.
4.  $\theta_{1/2}$  is the off-axis angle where the luminous intensity is 1/2 the peak intensity.

### Electrical Characteristics at $T_A = 25^\circ\text{C}$

Forward Voltage $V_F$ (Volts) @ $I_F$ 20 mA		Reverse Breakdown $V_R$ (Volts) @ $I_R = 100 \mu\text{A}$		Speed of Response $\tau_s$ (ns) Time Constant $e^{-t/\tau_s}$ Typ.	Capacitance C (pF) $V_F = 0$ , $f = 1 \text{ MHz}$ Typ.	Thermal Resistance $R\theta_{\text{J-PIN}}$ ( $^\circ\text{C}/\text{W}$ ) Junction to Cathode Lead
Typ.	Max.	Min.	Typ.			
3.5	4.0	5.0	45.0	500	97	260

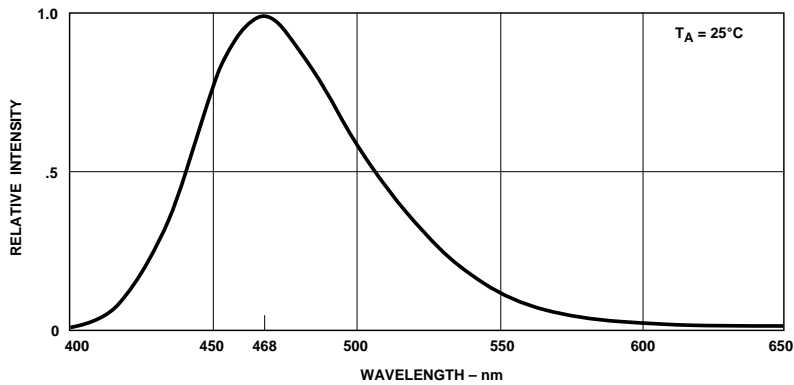

Figure 1. Relative Intensity vs. Wavelength.

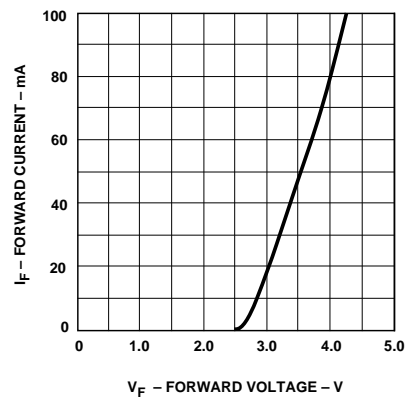

Figure 2. Forward Current vs. Forward Voltage.

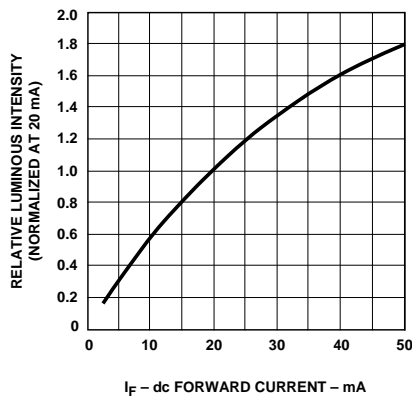

Figure 3. Relative Luminous Intensity vs. dc Forward Current.

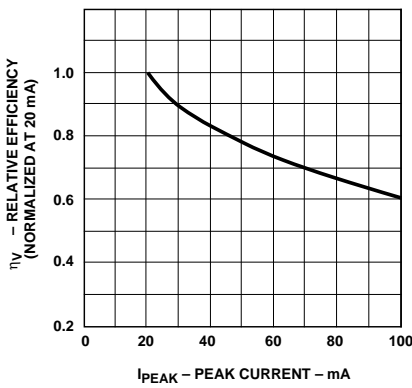

Figure 4. Relative Efficiency (Luminous Intensity per Unit Current) vs. Peak Current.

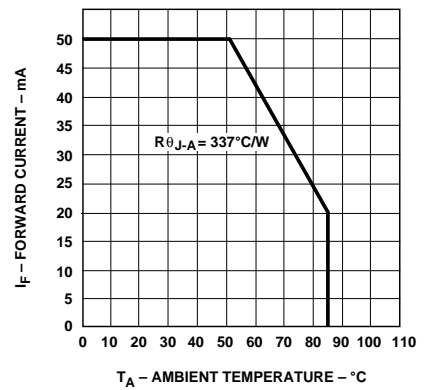

Figure 5. Maximum dc Current vs. Ambient Temperature. Derating Based on  $T_J$  Max. = 110°C.

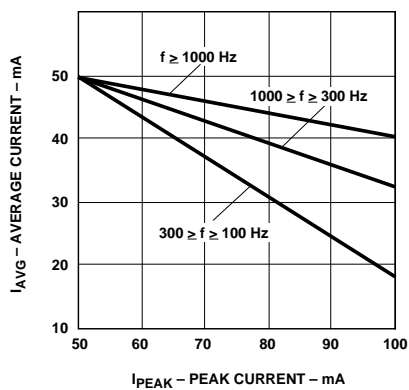

Figure 6. Time Average Current vs. Peak Forward Current as a Function of Pulsed Refresh Rate,  $f$  (Hz).

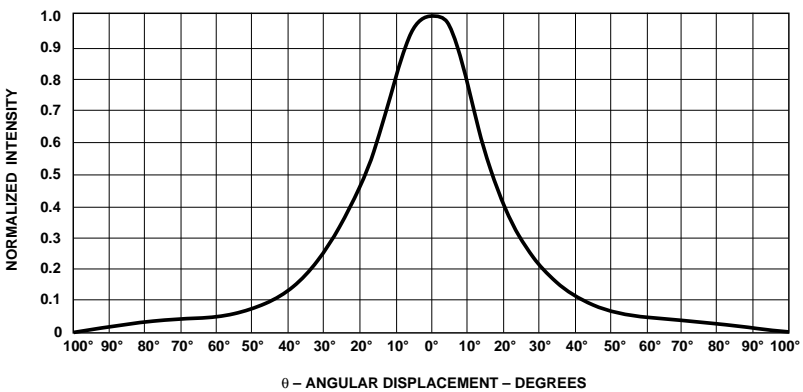

Figure 7. Normalized Luminous Intensity vs. Angular Displacement, HLMP-DB00.

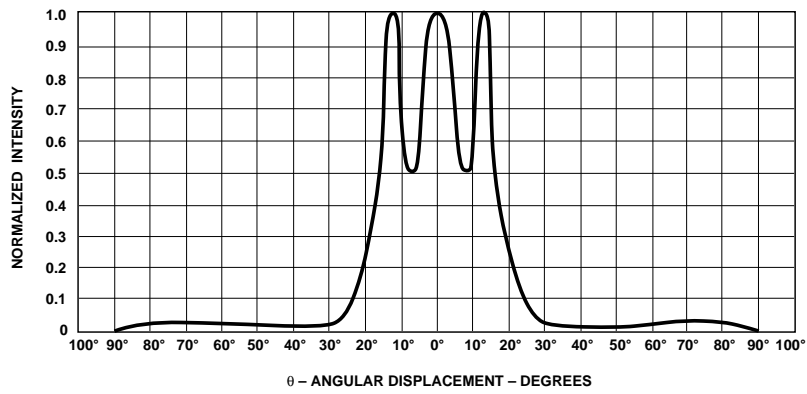

Figure 8. Normalized Luminous Intensity vs. Angular Displacement HLMP-DB15.